

# Ignition System

Job No.

15 — 20

The ignition system consists of the following parts:

- The ignition switch on the steering column bracket
- The ignition coil
- The distributor with contact breaker points
- The high-tension cables together with the spark plug connectors and
- The spark plugs.

## Function of the Ignition System:

When the ignition switch is switched on by turning the ignition key, the battery voltage is passed on to the ignition coil at terminal 15 (Fig. 15 — 20/1). The terminal 1 of the ignition coil is connected to ground by the low-tension cable via the distributor and its contact breaker points. The opening and closing of the contact breaker points causes the ignition coil to develop the ignition voltage in its high-tension section. The high voltage thus developed is passed from the terminal 4 via the high-tension cable to the distributor and is delivered to the various spark plugs by the rotor arm via the ignition cables.

The firing order is 1 3 4 2.

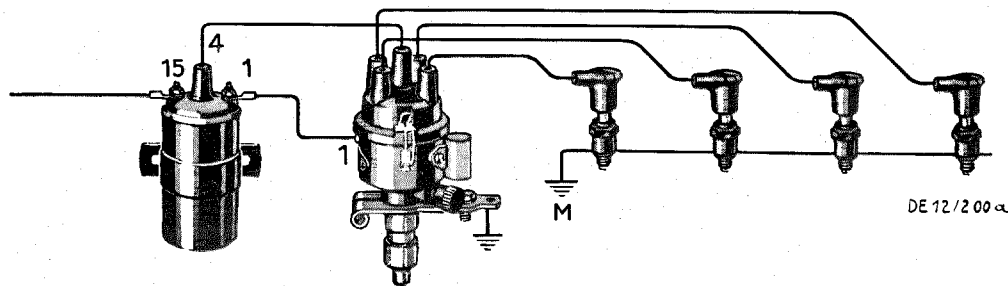

Fig. 15 — 20/1

## Removal and Installation of Ignition Switch

Job No.

15 — 21

### Removal:

1. Remove the steering column bracket with the lock (see Job No. 46 — 8).
2. Remove the round nut (80) from the stay bolt (79) (Fig. 15 — 21/1).
3. Push back the contact cap (77) from the steering column bracket (74). Then disconnect the electric cables and bend them to one side.
4. Push one of the two contact and holder springs for the bulb (81) to one side and take out the lamp.

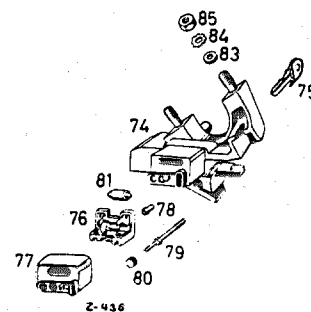

Fig. 15 — 21/1

74 Steering column bracket  
76 Ignition switch  
77 Contact cap  
78 Contact lifter

79 Stay bolt  
80 Round nut  
81 Tubular bulb

5. Unscrew the stay bolt (79). Then remove the ignition switch (76) from the steering column bracket (74).
6. Pull out the contact lifter (78).

**Installation:**

7. Put in the contact lifter (78). The insulated part of the contact lifter must point toward the ignition switch.
8. Connect the electric cables (Fig. 15—21/2), paying attention to the color coding:  
Connect:

The red cable (Lead No. 57)  
to terminal 30,

the black cable (Lead No. 10)  
and

the black/red cable (Lead No. 24)  
to terminal 15,

the blue cable (Lead No. 72)  
to terminal 61

(see also Job No. 54—1, Section A, Circuit Diagram of Main Wiring Harness, Cable Sheaf **7**).

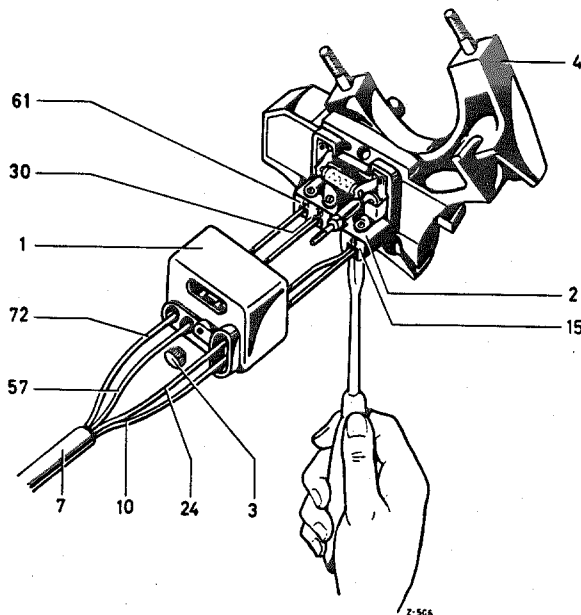

Fig. 15—21/2

- |                                      |                                  |
|--------------------------------------|----------------------------------|
| 1 Contact cap                        | 15 Terminal 15                   |
| 2 Ignition switch                    | 24 Lead No. 24 (black/red cable) |
| 3 Round nut                          | 30 Terminal 30                   |
| 4 Steering column assembly with lock | 57 Lead No. 57 (red cable)       |
| 7 Cable Sheaf <b>7</b>               | 61 Terminal 61                   |
| 10 Lead No. 10 (black cable)         | 72 Lead No. 72 (blue cable)      |

9. The remainder of the installation procedure is the reverse of the removal procedure.